

Nursery Superintendent, Oregon State Forest Nursery
Corvallis, Oregon

At forest nurseries of the Pacific Coast the weed control problem has always been and will continue to be the most expensive nursery operation. This is because weed growth is especially favored by the long growing season, mild winter temperatures, heavy winter rainfall, and heavy soil. If seedbed mulching was practiced, as it is at nurseries east of the Cascade Mountains; there would be less of this since mulch combined with freezing weather will keep down weed growth. However, since this is not the case at nurseries west of the Cascades, many weeds - especially annual bluegrass - grow throughout the wet winters and early spring months and thereby create an especially troublesome and costly weed control problem.

The Oregon State Forest Nursery near Corvallis, Oregon has a fairly heavy soil - Olympic clay loam. The usual weed control measures of spraying with chemicals, hand weeding, and cultivating with machines are used to cope with the problem. As a supplement to the use of Stoddard solvent and hand weeding, the Forestry Department personnel has developed an 8 row roto-tiller cultivator that has proven very successful in cultivating both conifer and broadleaf nursery stock. Trees up to 7 or 8 inches tall can be cultivated. This special machine is used on the rear on a tractor equipped with a hydraulic power lift. Two men, a tractor operator and a cultivator operator, are required. Construction details for this machine is shown in the accompanying drawings.

(See also Tree Planters' Notes Number 16 for a description of another rotary cultivator.)

OREGON STATE BOARD OF FORESTRY
SALEM, OREGON

POWERED CULTIVATOR
FOR DRILLED SEEDLINGS

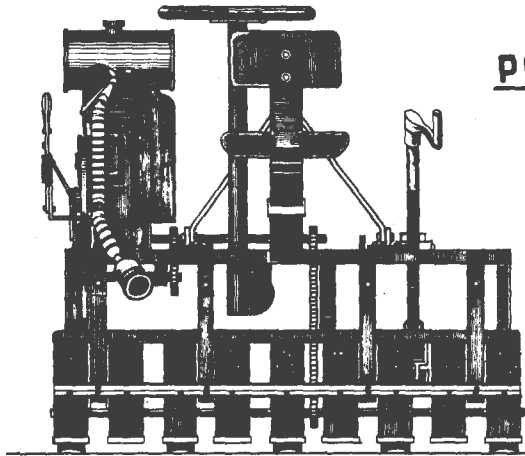

R E A R E L E V A T I O N

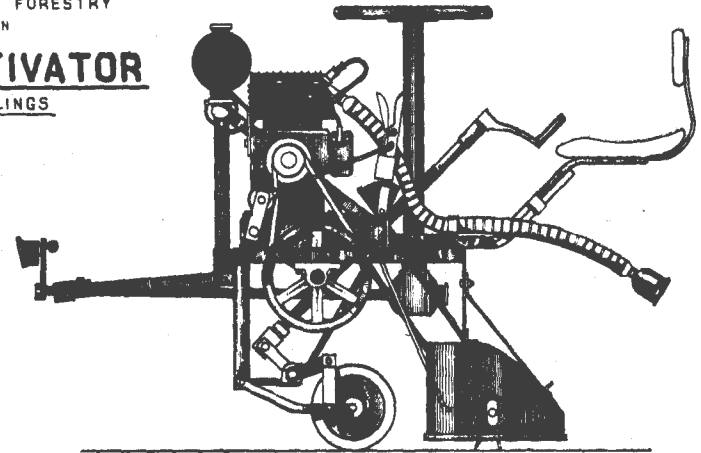

S I D E E L E V A T I O N

14

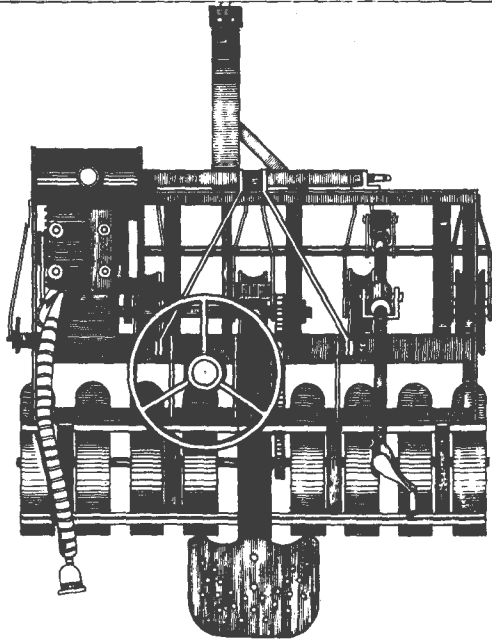

P L A N V I E W

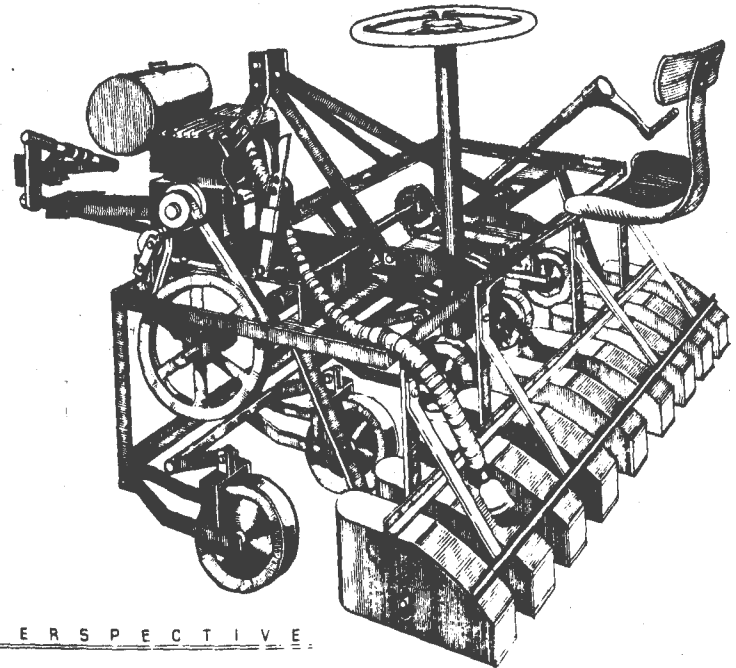

P E R S P E C T I V E

