

## SEED SOWING TOOL

Russell M. Burns  
Southern Forest Experiment Station,  
U.S. Forest Service,  
Oxford, Miss.<sup>1</sup>

A handtool for spot-sowing pine seeds has been developed and tested in north Mississippi. This tool is similar in some respects to that of Woods.<sup>2</sup> It has a rake at the lower end for baring mineral soil, and the hollow handle contains a metering device for dispensing seed. It is all metal, weighs 4 1/2 pounds, and holds a day's supply of seed.

This tool was tested on 20 acres of blackjack-post oak ridges in January 1960. Four 8-hour man-days were required to seed the tract at 6- by 7-foot spacing--about 1,000 seed spots per acre. Three stratified, repellent-treated loblolly pine seeds were sown on each spot. By June 1960 almost 60 percent of the spots were stocked with live seedlings, even though the spring had been unusually dry.

The tool can be constructed at a machine shop for approximately 30 dollars. Details are shown in figure 1. The body (1) is 1 1/2 -inch diameter aluminum pipe threaded on the upper end for a brass cup (2). The head of the tool (3) was force-fitted and retained in the other end of the pipe with a tapered steel pin (4).

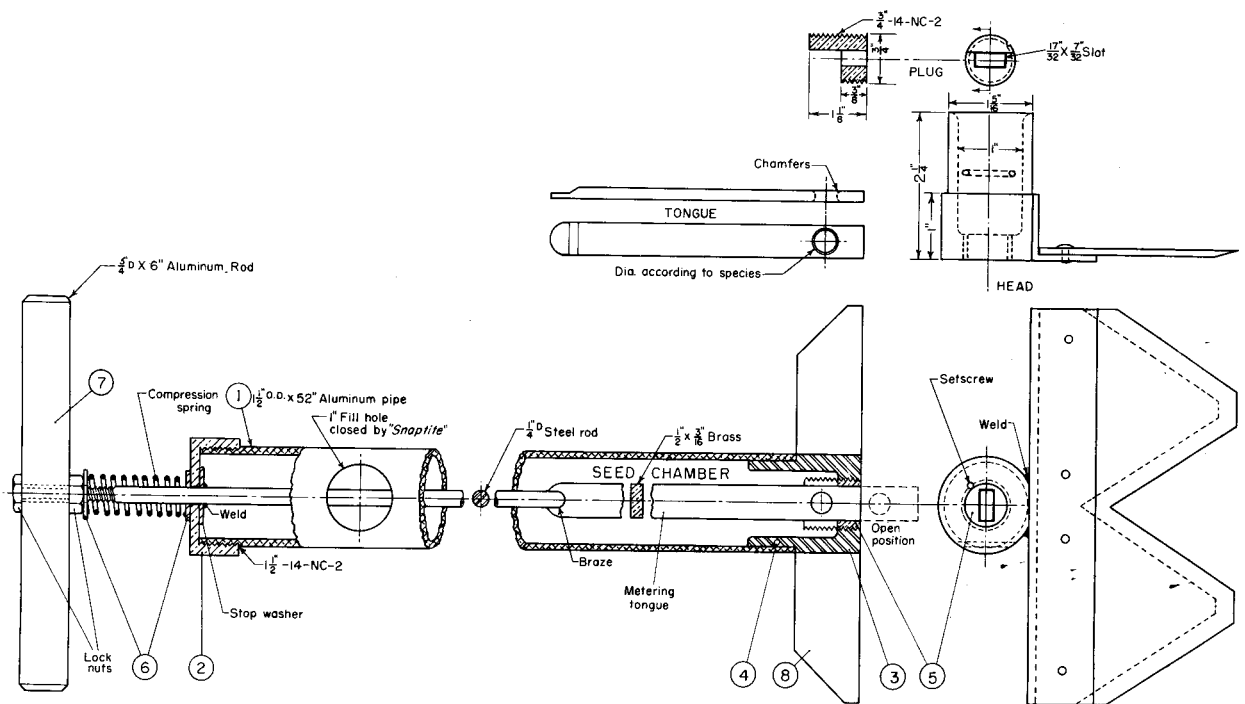

Figure 1.--Construction details.

<sup>1</sup>Oxford Research Center, maintained in cooperation with the University of Mississippi.

<sup>2</sup>John B. Woods, Jr. The direct-seeding gun, Jour. Forestry 43: 39-40, illus. 1945.



The 2 1/4-inch long head was turned from 1 1/2-inch diameter cold-rolled steel stock. A 3/4-inch diameter threaded brass plug (5) was affixed in the end of the head with a set screw. The plug, with a 7/32- by 17/32-inch rectangular slot through its center, acts as a discharge aperture for a brass metering tongue.

The 1/2- by 5-inch tongue was cut from 3/16-inch brass plate. A chamfered hole large enough to accommodate the required number of seeds (3/8-inch diameter for 3 repellent-coated loblolly or slash pine seeds) was drilled 5/8 inch from one end. The other end was brazed to a 1/4-inch diameter steel rod, 51 inches long.

The upper end of the rod was passed through a 9/64-inch hole in the brass cap (2) and threaded for approximately 1 3/4 inches to accommodate the compression spring, lock nuts, washers (6), and tapped solid aluminum handle (7) of the handle assembly. A stop washer was welded to the rod to prevent the spring from drawing the tip of the metering tongue from a position flush with the outside of the brass plug (5).

A 1 -inch hole for filling the tool was drilled 2 1/2 inches from the capped end of the pipe and through its upper surface. An adjustable vacuum bottle stopper reduced in length and bent to conform to the curvature of the pipe was used as a stopper.

Figure 2.--The tool in operation.

One-half of a standard firerake head (8) was arc-welded to a flattened shoulder of the head (3) so that the slot in the brass plug (5) and the head of the rake were parallel. The gripping surface of the pipe was improved by wrapping it with plastic electrical tape.

The tool can be operated efficiently as follows: grasp the handle (positioned about 20° from vertical) in one hand, and the taped pipe in the other (fig. 2). Rake a spot, ending the stroke with the heel of the hand against the hip joint. Compress the spring by leaning the body against the hand; this will discharge the seed. Step forward and press the seeds into the soil with the foot.

The spots are large enough to be readily apparent. This is helpful in orienting successive lines of spots and in maintaining an even spacing between rows.