

SINGLE-ROW, TRACTOR-MOUNTED TREE LIFTER FOR HARDWOODS

Dean W. Einspahr

Research Assistant, The Institute of Paper Chemistry  
Appleton, Wisconsin

Proper handling of experimental seedlings becomes quite a problem when large-scale tree breeding and testing programs are instituted. Often large numbers of experimental lineout stock must be lifted for field planting. Experimentally it is desirable to have the trees handled carefully, uniformly, and as expediently as possible.

The Institute of Paper Chemistry's forest genetics program requires the handling of large numbers of aspen seedlings. To reduce the problem of handling the experimental trees a single-row tree lifter was designed and built (figs. 1 and 2). The lifter is attached by a three point hitch that fits the hydraulic system of either the Ford or Ferguson tractor.

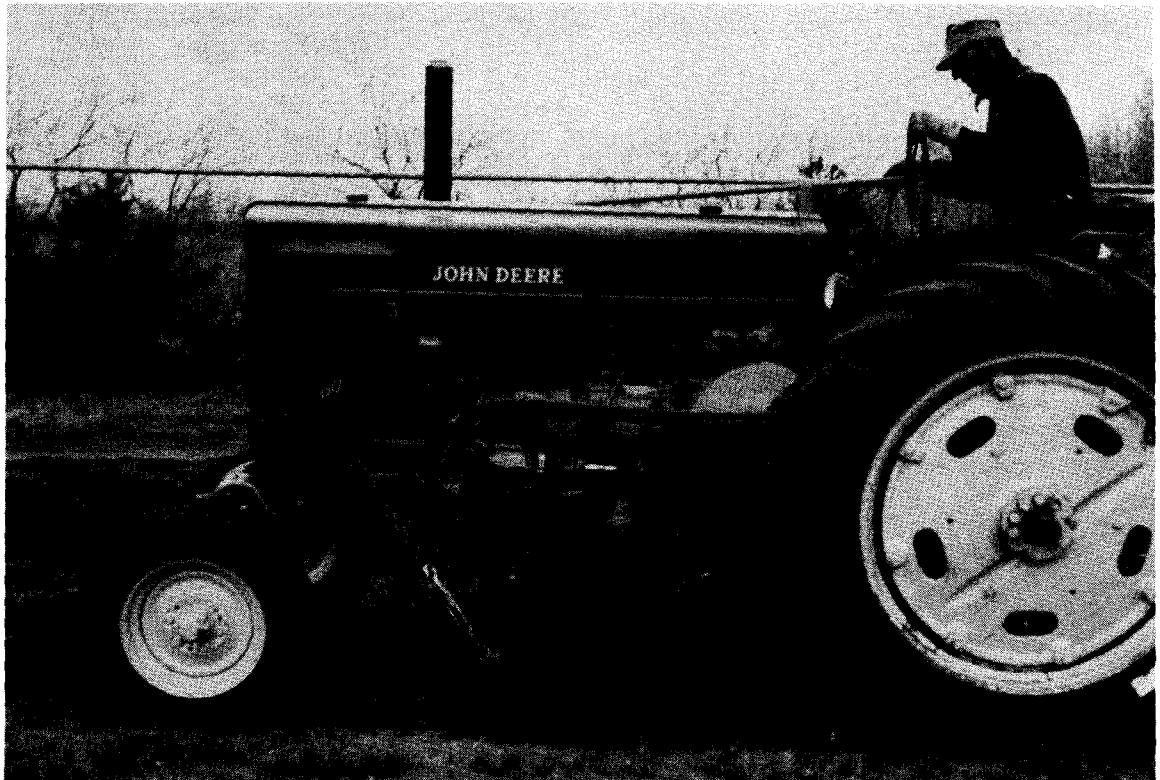

Figure 1. This tractor-mounted tree lifter was designed to undercut, side prune, and lift experimental aspen seedlings.

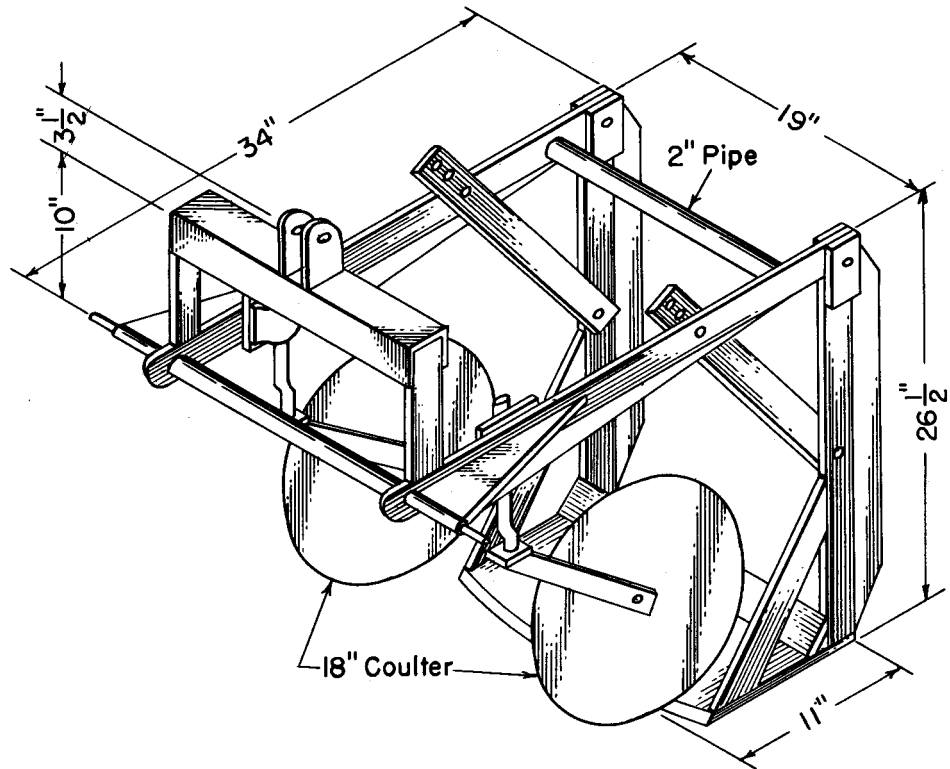

Figure 2. -Overall dimensions of the single-row tree lifter. The basic structure is made from 1/2"x2" cold rolled steel.

By means of the hydraulic control the lifter can be run at any desired depth from 0 to 9 inches. The 18-inch rolling coulters, which are mounted on the frame in front of the lifter shoe, prune the side roots. The lifter shoe prunes the lower roots, lifts the trees, and loosens the soil so the "bare-rooted" trees can be pulled from the soil with a minimum of injury to the root system.

Cost of two 18-inch rolling coulters completely equipped for mounting runs from \$40 to \$50. The materials and labor for the remainder of the machine runs close to \$80.