

# Geothermal Energy for Greenhouses

Jacky Friedman

**Jacky Friedman** is Nursery Manager, IFA Nurseries, Incorporated, 1205 S Spring Street, Klamath Falls, OR 97601; Tel: 541.850.0952; E-mail: [jfisher@ifanurseries.com](mailto:jfisher@ifanurseries.com).

Friedman, J. 2009. Geothermal energy for greenhouses. In: Dumroese, R.K.; Riley, L.E., tech. coords. 2009. National Proceedings: Forest and Conservation Nursery Associations—2008. Proc. RMRS-P-58. Fort Collins, CO: U.S. Department of Agriculture, Forest Service, Rocky Mountain Research Station: 17–19. Online: [http://www.fs.fed.us/rm/pubs/rmrs\\_p058.html](http://www.fs.fed.us/rm/pubs/rmrs_p058.html).

**Keywords:** alternative energy, heating systems

Geothermal energy is heat (thermal) derived from the earth (geo). The heat flows along a geothermal gradient from the center of the earth to the surface. Most of the heat arrives at the surface of the earth at temperatures too low for much use. However, plate tectonics ensure that some of the heat is concentrated at temperatures and depths favorable for its commercial extraction (fig. 1). The water may circulate to a depth of at least 4,270 m (14,000 ft). It is then heated and moves upward along fault zones and fractures.

Geothermal energy use in greenhouses is not a new concept. Bananas are grown in greenhouses in Iceland using geothermal energy.

## Geothermal Energy Use in Klamath Falls

Klamath Falls, in southern Oregon, is located approximately 1,300 m (4,300 ft) above sea level (fig. 2). The Klamath Basin occupies the northwest corner of the Basin and Range Geological Province. This Province stretches south as far as Mexico and east to Utah. The north-south running ranges that separate the broad, flat basins are actually the fault lines between two separate blocks—one that has been pushed up (horst) and another that has been pushed down (graben). Extensive geological mapping of the Klamath Basin has found hundreds of these fault lines.

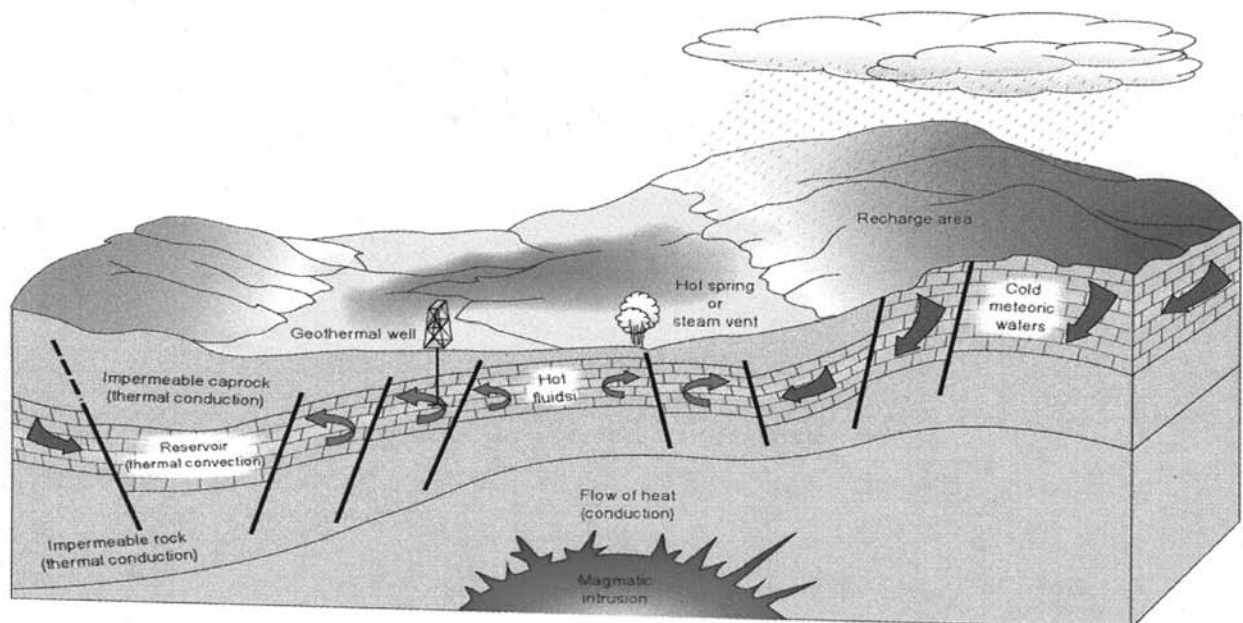

**Figure 1.** Plate tectonics allow geothermal heat to flow along a gradient from the center of the earth to the surface.



**Figure 2.** Klamath Falls is located in southwest Oregon in the northwest corner of the Basin and Range Geological Province.

The hot water in the Klamath basin probably originates as seepage from the Cascade Range to the west, Crater Lake to the north and, in part, from seepage from Upper Klamath Lake. The City of Klamath Falls is in a Known Geothermal Resource Area (KGRA). Records show native Indians utilizing the hot water for over 10,000 years, and the early settlers believed the “hot springs” would heal their ailments.

In 1982, the City of Klamath Falls constructed a “district heating system” (DHS) to provide the geothermal resource to the downtown area. The DHS was originally designed for a thermal capacity of 20 million BTU/hour. In 1992, however, only 25% of the DHS was being utilized, and a marketing effort began to attract new users.

The DHS currently provides geothermal energy for heating purposes to the Klamath Falls waste water treatment plant, approximately 37,160 m<sup>2</sup> (400,000 ft<sup>2</sup>) of city

buildings, some of the schools, the library, U.S. Post Office, 9,750 m<sup>2</sup> (105,000 ft<sup>2</sup>) of heated sidewalks, 350 private homes, and a new development, including a hotel and individual businesses.

Klamath Falls has two main systems. The “closed loop” system is typically used with private homes. The “open loop” system is used for much of the downtown area, in which any water removed from the aquifer must be replaced. All open loop systems have a production well and an injection well (fig. 3). The production well pumps are vertical line shaft pumps, oil lubricated, with variable speed drives. Only one production well is used at a time depending on the demand for heat.

Approximately 1,340 m (4,400 ft) of 20-cm (8-in) steel pipes convey the geothermal flow from the production wells to the heat exchanger. The geothermal flow is then injected back into the aquifer via the injection well.

The geothermal flow goes through the heat exchanger and the heat is transferred to a secondary system. The heat exchanger transfers 10,000 BTU/hour. The secondary water system uses municipal water. The hot water is pumped through a loop of pipeline around the downtown area of Klamath Falls. Each user of the system has a heat exchanger, and the heat is then transferred to their individual tertiary system.

The DHS is designed to deliver heating energy. The water flow is merely a means to convey the energy. The capacity to deliver heat is limited both by the flow capacity of the system and what the customer does with the heating water before sending it back. The heat delivered by the water depends on both the flow and the temperature change of the water. Flow is essentially fixed by the hardware selected in the design—pumps, pipes, control valves, heat exchangers, and so on. Any significant increase in flow requires larger equipment and increased power.

Recent improvements to the district heating system have increased the maximum capacity of the system to 36 million BTU/hour. The geothermal energy is currently available yearly from September to July.

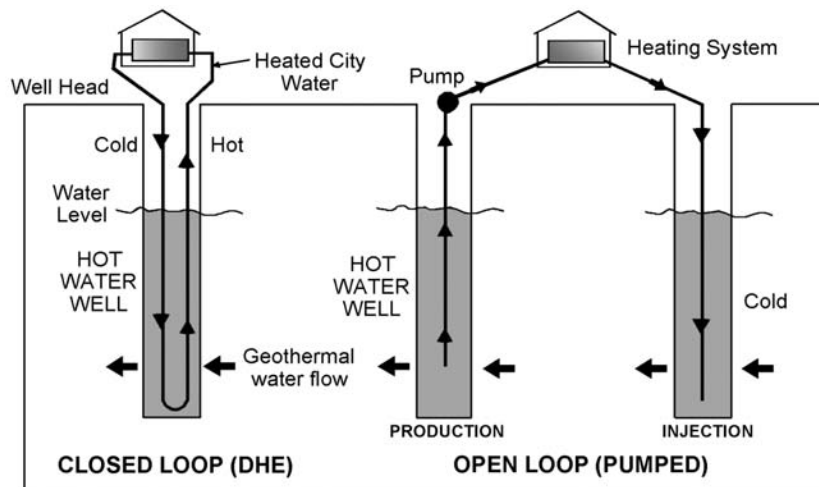

**Figure 3.** Two systems, “closed loop” and “open loop,” are used in the various geothermal heating systems in Klamath Falls, OR.

## IFA Nursery, Incorporated Geothermal Use

In 2001, IFA Nurseries, Incorporated (IFA) commenced the building of a new state-of-the-art greenhouse facility in Klamath Falls. The nursery now has 16,260 m<sup>2</sup> (175,000 ft<sup>2</sup>) of greenhouse space for growing seedlings for reforestation. The location was chosen for various reasons, but one incentive was the use of the DHS.

IFA's hot water supply from the city reaches our heat exchanger at about 83 °C (182 °F), and the supply temperature to our tertiary loop is about 82 °C (180 °F) (fig. 4). A computerized system monitors greenhouse temperatures and heat demand, and, in turn, an automatic valve opens the city supply line to allow flow through the heat exchanger. Valves located on the unit heaters at the greenhouses also open and close as the demand for heat fluctuates. Hot water flows into the forced air units on the unit heaters and warm air is forced through ducting and under-bench convection

tubing. In addition to heating the greenhouse, we heat our main operations building and offices.

Several factors should be taken into account when looking at the economics of such a project. IFA chose to locate in Klamath Falls for several positive reasons, and the geothermal energy was just one of them. Users of the DHS are charged per Therm (100,000 BTU). The City-metered geothermal rate is set at 80% of the current commercial natural gas rate, with a rate increase of no more than 10% per year.

IFA saves a considerable amount of money on energy costs by using geothermal energy versus natural gas. The initial start-up costs of such a project are high, with much specialized and high-cost equipment required. A level of expertise was required in this project and we are grateful for the expertise at Oregon Institute of Technology Geothermal Heat Center for their assistance throughout the project. IFA received the Governors Award in Oregon in 2001 for best environmental construction for the project in Klamath Falls.

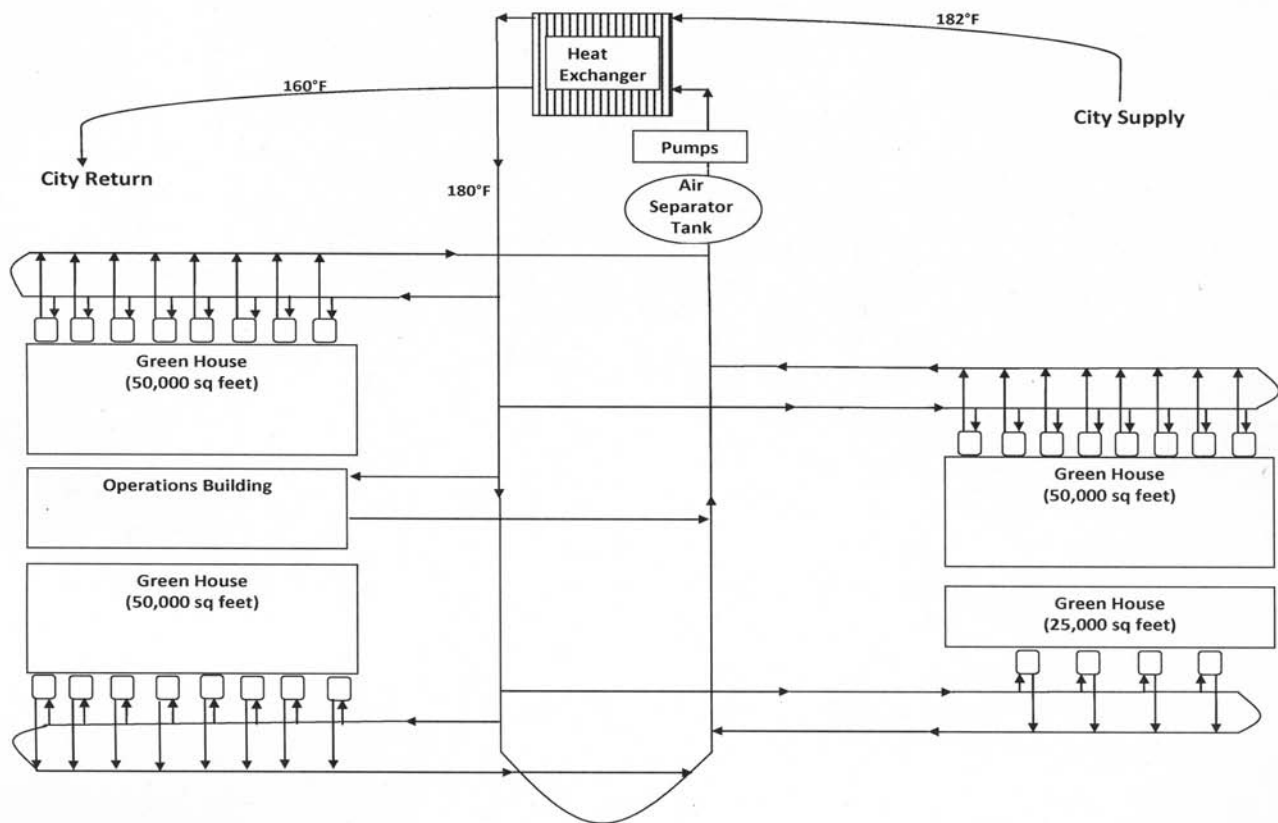

Figure 4. Tertiary heating loop for greenhouses and operations building at IFA Nurseries, Incorporated in Klamath Falls, OR.

The content of this paper reflects the views of the authors, who are responsible for the facts and accuracy of the information presented herein.